

MFA Griplate™ Series - Aluminum



Expansion joint cover system

Innovative solutions for Pedestrian Traffic

The MFA Griplate™ expansion joint cover solution is a Patent pending slip resistant cover plate utilising an epoxy based carborundum in fill that helps provide a long wearing safe slip resistant surface designed for environments such as:

- All types of retail centres
- Indoor and outdoor public spaces
- Pedestrian walkways
- Airports, hotels, stadiums, etc.

Features

- Griplate™ Cover Plate, conforms to AS NZS 4586 for slip resistance. Classified “v” rating, highest classification.
- Designed to comply with AS1170.1 Live floor loadings for retail areas
- Structural Grade Aluminium 6061
- Can be installed to suit all floor types including tile, carpet, stone, vinyl, concrete and epoxy floors.

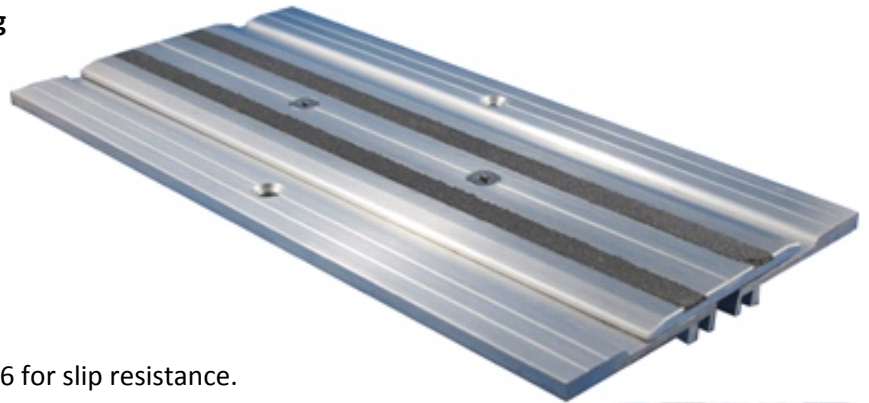

Long wearing epoxy based carborundum infill's

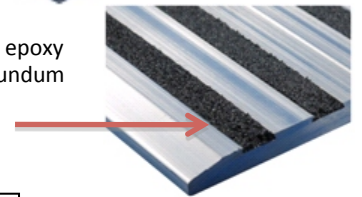

Benefits

- Low maintenance though design simplicity
- Griplate™ Reduces risk of slips and falls and associated public liability
- Economical solution for slab on ground applications
- Structural Grade materials ensures extended serviceability.

Other Options

- Water and Fire barrier
- Recommended Bedding Materials:
 - Pedestrian traffic: Ramset Premier Grout
 - Vehicle traffic: Miska FC122 Epoxy Mortar
- For full range of Griplate see your Miska representative.

AS4586 Test Certified

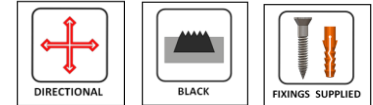

Options Available:



Additional Services

Loading
Miska provides loading calculations based on specific project requirements.

Installation
Installation instructions provided on request, Miska can also provide contacts for approved installers in your area. Please contact your representative for details.

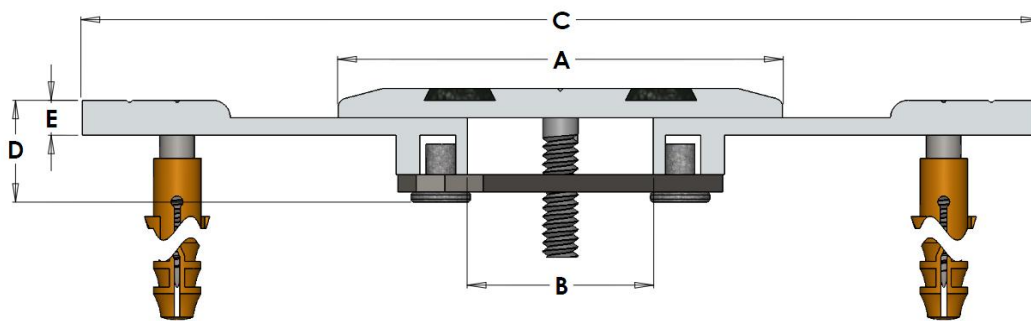

Block out Dimensions 16 H x 13 W		Physical Data									All measurements stated are in mm.	
Code	A = Coverplate			B = Gap				C = Exposed Width			D	E
	Width	Thickness		Min	Mid	Max	mvmt	Min	Mid	Max		
		Overall	Loading									
MFA75S2GPLT	75	5	3	7	31	55	48	137	161	185	17.5	6
MFA100S2GPLT	100	6	4	20	50	80	60	150	180	210	17.5	6

Disclaimer: The information contained in this publication is intended to give a fair description of the products and their capabilities. No responsibility or liability by the manufacturers will be accepted for misuse, misreading or deviation from the recommended guidelines of these products. As new technology is introduced, or industry standards are altered, Miska reserves the right to alter the information without notice.

Rev.03
Feb 2011

Miska (Aust) P/L
(A business unit of ITW Australia)
P.O. Box 1021 Archerfield, Queensland, 4110.
Telephone: 61 7 3277 7077 Facsimile: 61 7 3277 8858
Web: www.miska.com.au