

DYNABOLT/INSTALLATION INFO

DYNABOLT M8 X 90 CODE DP08090 HOLE ϕ 10mm

DO NOT SCALE

MISKA AC100GPLT

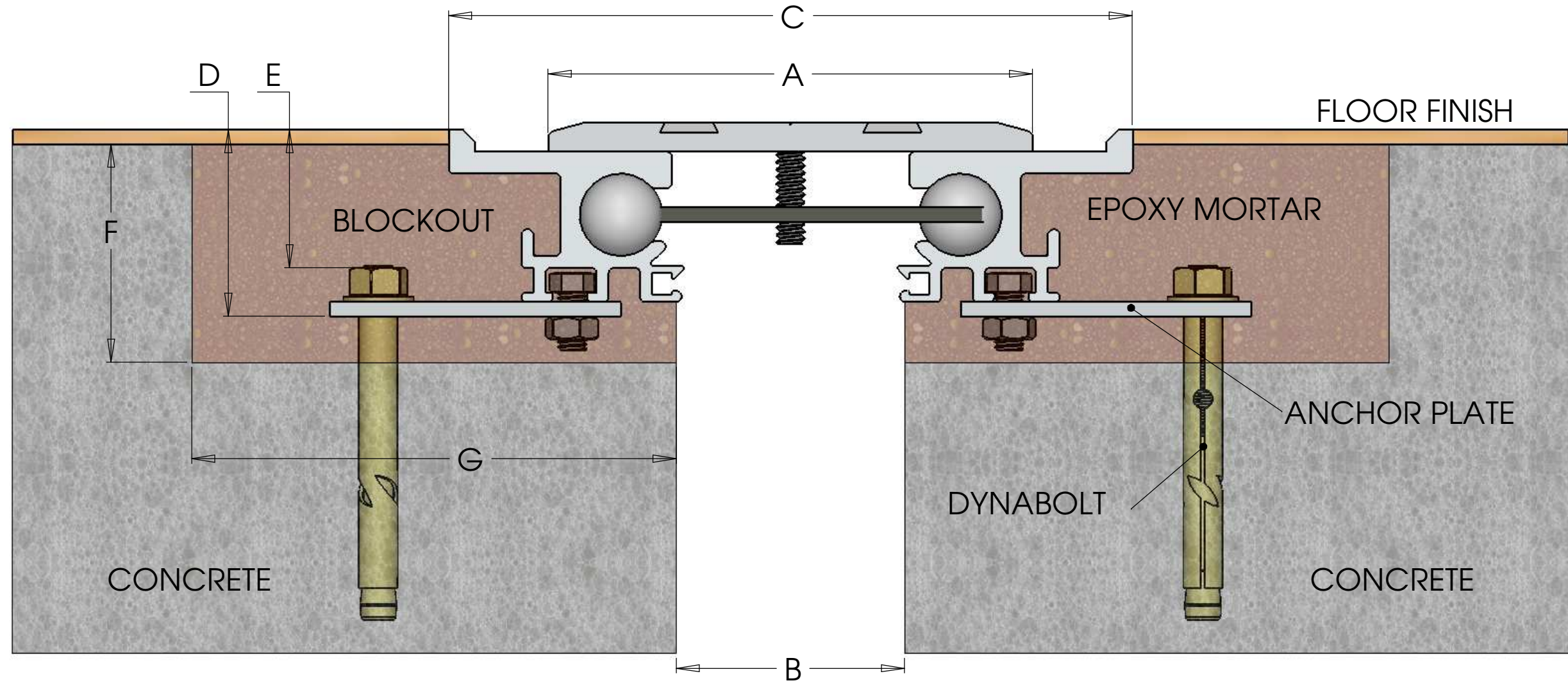

AC100GPLT

A	COVERPLATE	6 X 100mm
B	GAP (MIN, MID, MAX)	(17,47,77)mm
C	OVERALL WIDTH (MIN, MID, MAX)	(111,141,171)mm
D	BASE HEIGHT	38mm
E	COVERAGE	28mm
F	BLOCKOUT HEIGHT	45mm
G	BLOCKOUT WIDTH	100mm
	MOVEMENT	60mm

PRODUCTION DRAWING

ENGINEERED ARCHITECTURAL PRODUCT
 PHONE (+617) 3277 7077
 (+617) 3277 8858
 EMAIL ENQUIRES @ MISKA.COM.AU
 WEB WWW://MISKA.COM.AU



DRAFTED: PG	DATE: 30.11.10
VERIFIED: NJ	DATE:
APPROVED:	DATE:
Q.A.:	DATE:
SCALE:	1:1
CONCEPT NO:	-

TITLE:
AC100GPLT

DWG NO: P000083

SHEET 1 OF 2

SHEET SIZE A3

REVISION:

0

THIS DRAWING IS COPYRIGHT AND THE PROPERTY OF MISKA PTY. LTD. AND MUST NOT BE REPRODUCED WITHOUT WRITTEN PERMISSION